

Metal-Clad, Gas-Insulated
AC Voltage Test Systems,
Types WP...G and WPG...G,
WRV...G and WRVG...G



Application

Alternating voltage (HVAC) is the most important test voltage for all components of electric power systems, in particular as most HVAC tests are connected with sensitive PD measurement. When gas-insulated substations (GIS) and transmission lines (GIL) or their components shall be tested, the conventional air-insulated HVAC test systems (see **Catalog Sheet 1.10**) are not well fitting to the very compact test objects. Efficient factory testing requires the direct connection of the HVAC test system to a gas-insulated test bus with several junctions for test objects.

Each junction of the test bus is equipped with a combination of disconnecter/grounding switch. This enables e.g. assembling of a first test object at junction 1, simultaneous testing of a second test object at junction 2 and disassembling of a third test object at junction 3. The HVAC test system is connected to a further junction of the test bus. Whereas test busses are realized by the GIS manufacturers themselves, HIGHVOLT supplies different types of metal-clad HVAC test systems, well adapted to the kind of the test (quality tests in factory on GIS components (e. g. spacers) or complete GIS bays, respectively on-site tests on GIS or GIL).

HVAC test systems, type WP...G and WPG...G generate the test voltage of fixed frequency 50 or 60 Hz by a transformer. Therefore they are mainly applied for **quality tests in factory**. The transformer can be a powerful oil-insulated metal tank transformer with an oil-to-SF₆ bushing (see **Data Sheet 1.12**) or a SF₆-insulated transformer for short-time operation (see **Data Sheet 1.71**).

HVAC resonant test systems of variable frequency, types WRVG...G & WRV...G, generate a HVAC test voltage of a frequency depending on their capacitive load (see **Data Sheet 8.04**). They are very well introduced for on-site tests because of the accepted wide frequency range (see IEC 60060-3). But in case of test objects of capacitive load within a narrow frequency band, also WRV-systems fulfill the requirement for HVAC factory tests (IEC 60060-1: 45...65 Hz). For economic reasons they are more and more used for factory tests, too.

The block diagram of the HVAC test system described here (Fig. 1) is identical to that of conventional HVAC test systems with test transformers.

Advantages of metal-clad, gas-insulated test systems:

- The metal-clad design is a perfect shielding for sensitive partial discharge (PD) measurements as well as for protection of the personal.
- No special HV test field required, the test system can be easily arranged in a production hall according to the technological requirements.
- Space demand is lower than one quarter of a conventional, air-insulated HVAC test system.
- HVAC test systems, types WRVG...G, are minimum in weight, size, power demand – and also in price!
- Wide range of rated parameters (voltage, power, duty cycle, frequency) available.

Principle Test Circuit

More details are described in **Catalogue Sheet 1.10**, respectively to that of variable frequency resonant systems for on-site applications (**Catalogue Sheet 8.04**). Also the components for power feeding as well as for control and measurement (up to computer control with remote access) are identical. Different is the “metal-clad, gas-insulated” design of the HV test circuit only.

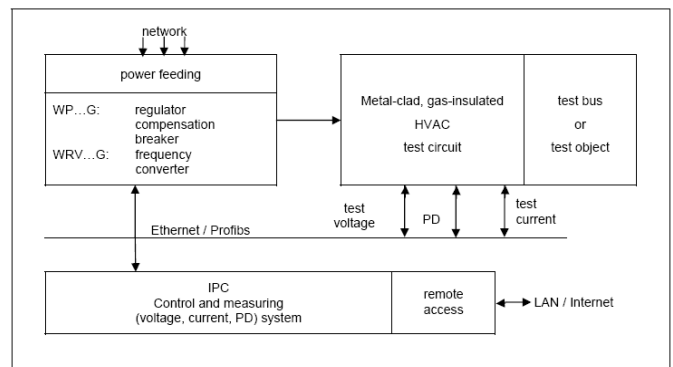

Fig. 1: Block diagram of a HVAC test system

The test circuit includes the HVAC generator (HV transformer or HV reactor), a voltage divider and components for PD measurement (Fig. 2). The compact HIGHVOLT design avoids unnecessary flanges. Therefore one cross piece connects the output of the generator with the PD coupling capacitor, the PD calibration injector and the test object. The long arm of the cross contains an impedance which protects the generator in case of breakdown of the test object and acts also as a PD blocking impedance for noise reduction. If over voltages due to reflections are extremely high an additional protection resistor can be integrated. All components filled with SF₆ of 5 bar (absolute) are described in **Data Sheets 1.72 to 1.75**.

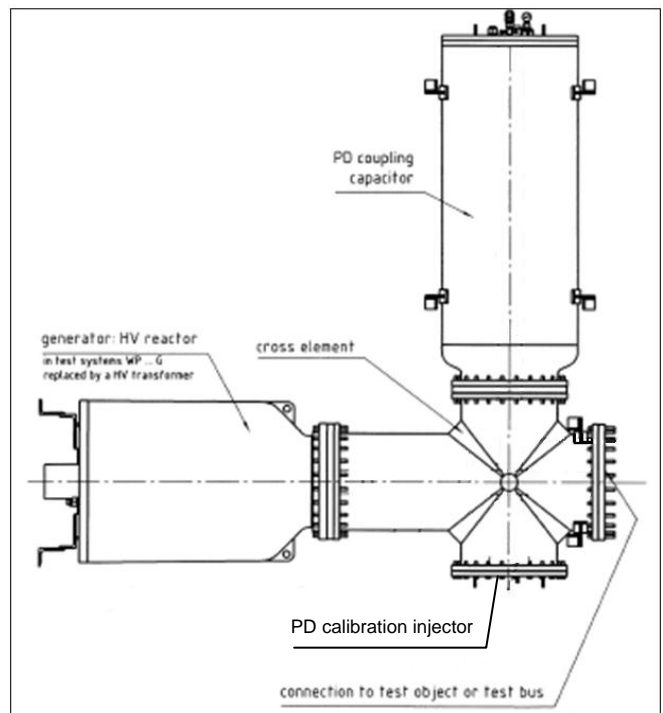

Fig. 2: Metal-clad, gas-insulated HVAC test circuit, type WRVG...G

Metal-Clad HVAC Test Systems with Transformers

Systems with oil-insulated transformers up to 1000 kV, types WP...G

The systems, types WP...G, are based on transformers described on **Data Sheet 1.12**, but equipped with an oil-to-SF₆ bushing. These transformers are of high power and for longer duty cycles up to continuous operation. Systems WP...G are completed by the following components:

- switchgear cubicles (**Data Sheet 1.14 or 1.15**),
- compensation reactors (**Data Sheet 1.17 or 1.18**),
- regulating transformers (**Data Sheet 1.26 or 1.27**),
- metal-clad connection and junction elements (**Data Sheet 1.72**),
- metal-clad elements for PD measurement (**Data Sheets 1.73, 1.74, 6.12**),
- control and measuring systems (**Catalog Sheet 1.52** with Data Sheets mentioned there),
- and PD measuring systems (**Data Sheet 6.21 or 6.41**),
- optional: SF₆-to-air bushing (**Data Sheet 1.75**).

The higher the rated voltage the higher is the benefit of metal-clad HVAC test systems compared with conventional air-insulated test systems (Fig. 3). Therefore the standard ratings for systems type WP...G are 400 kV/2 A; 500 kV/2 A; 600 kV/1.7 A, 800 kV/1.25 and 1000 kV/1A (continuous operation). On request, also systems WP...G for lower voltages can be supplied, but in the range below, the power and the duty cycle of systems WPG...G with SF₆-insulated transformers might be sufficient (see right column).

Type designation for a metal-clad, gas-insulated HVAC oil-insulated transformer test system with WP a/b G, with "a" the rated power and "b" the rated voltage are as follows.

Example: WP 1000/800 G is a metal-clad, SF₆-insulated test system of 1000 KVA and 800 kV (current 1.25 A).



Fig. 3 (left): Metal-clad HVAC test system, type WP 400/800 G for routine testing of GIS spacers (courtesy of Hyundai)

Fig. 4 (right): Metal-clad HVAC test system, type WPG 250/750, for GIS routine testing (courtesy of ABB Xiamen/China)

Systems with SF₆-insulated transformers up to 1000 kV, types WPG...G

The systems, types WPG...G, are based on transformers described on **Data Sheet 1.71**, which can directly be flanged to metal-clad, gas-insulated components. SF₆-insulated transformers are of relatively low power and short duty cycles. The maximum total load (test object, coupling capacitor, and metal enclosures) is in the order of 1000 pF. Consequently, the test object capacitance should remain below 600 pF. Therefore, systems types WPG...G are well-suited for few short time tests per day on objects of low capacitance by 50 or 60 Hz test voltages. Useful applications are compact test fields for gas-insulated voltage transformers of GIS. WPG...G are completed by the following components

- switchgear cubicles (**Data Sheet 1.14**),
- compensation reactors (**Data Sheet 1.17**),
- regulating transformers (**Data Sheet 1.26**),
- metal-clad connection and junction elements (**Data Sheet 1.72**),
- metal-clad elements for PD measurement (**Data Sheet 1.73, 1.74, 6.12**),
- control and measuring systems (**Catalog Sheet 1.52** with Data Sheets mentioned there),
- PD measuring systems (**Data Sheet 6.21 or 6.41**),
- optional: SF₆-to-air bushing (**Data Sheet 1.75**).

The standard ratings for systems, types WPG...G, (for a 15 min. duty cycle at rated parameters per day) are 230 kV/0.2 A, 325 kV/0.1 A, 510 kV/0.2 A, 750 kV/0.3 A and 1000 kV/0.4 A. For shorter duty cycles the currents can be increased (e.g. for 2 min/day more than doubled), for lower currents, the duty cycles can be increased. The available power can be increased by compensation on the HV side using a SF₆-insulated reactor (**Data Sheet 8.13**).

Type designation for a metal clad, gas-insulated HVAC test system with a SF₆-insulated transformer is WPG a/b G, with "a" the rated power and "b" the rated voltage. Example: WPG 90/510 G is a metal-clad, test system with a SF₆-insulated transformer of 90 kVA and 510 kV.



Metal-Clad HVAC Resonant Test Systems of Variable Frequency

Metal-clad HVAC resonant test systems of variable frequency type WRV...G and WRVG...G are very well introduced for on-site testing of GIS and GIL (see **Catalog Sheet 8.04**). Their characteristic is the dependence of the test voltage frequency (equal to resonant frequency) on the total load capacitance and the fixed inductance of the metal-clad, SF₆-insulated reactor (**Data Sheet 8.13**). The total load capacitance (C), consists of the test object (C_{T0}) and the basic load (C_{BL}) by the enclosure and the PD coupling capacitor (C = C_{T0} + C_{BL}). Resonance is reached when the losses in the circuit are supplied with the resonance frequency by a frequency converter. Rated voltage U_R and rated current I_R are characteristics of the reactor, they determine the maximum possible load

$$C_{\max} = C_{T0\max} + C_{BL} = L (I_R^2 / U_R^2).$$

The load C_{max} is connected with the minimum test voltage frequency f_{min}, whereas f_{max} is related to the system without test object (C_{min} = C_{BL}; C_{T0} = 0).

Selection of a test frequency and load range. The frequency range (f_{min} ≤ f ≤ f_{max}) determines the load range. From a physical point of view, it can be such that the stresses and discharge processes in the tested insulation correspond to those of power frequency (50 or 60 Hz). In practice the frequency range is determined by international standards. Standards for on-site testing (e.g. IEC 60060-3, for GIS IEC 62271-203) allow a sufficiently wide range of test frequencies, e.g. for GIS 10 to 300 Hz are allowed.

For routine and type testing in factory, alternating voltage of power frequency is defined with f = 45...65 Hz. With f_{max}/f_{min} = 65/45 ≈ √2 one gets a load range

$$C_{\max} / C_{\min} = (f_{\max} / f_{\min})^2 = 2.$$

Because of C_{min} = C_{BL}, this means for the load range of test objects 0 ≤ C_{T0} ≤ C_{BL}. For routine tests this is only acceptable, if not too large units are tested. A system type WRVG...G can be better used if a wider frequency range can be applied. This could be done for routine tests if GIS manufacturer and user agree about that. For internal quality tests on GIS components wider frequency ranges are very common (Fig. 5).



Fig. 5: Test systems WRVG 0.65/1000 G and WRVG 1.5/600 G for GIS spacer testing (courtesy of Hyosung Industries/Korea)

A range f = 45...90 Hz allows a much better utilization of the test system due to the fact that 0 ≤ C_{T0} ≤ 3 C_{BL}. Some suppliers use one system for both, factory and on-site tests (Fig. 6).

The systems type WRVG...G are resonant circuits (see **Catalog Sheet 8.04**) based on reactors described on **Data Sheet 8.13**. The reactors type DEG are characterized by a frequency range f = 50...300 Hz, their rated voltage U_R and current I_R. Two reactors can also be switched in series for the generation of higher voltages or in parallel for the generation of higher currents. Consequently, a variety of test systems WRVG...G well adapted to the demand of GIS and component testing can be designed, by using the following additional components:

- control and feeding units (frequency converter, **Data Sheet 8.31 or 8.32**),
- exciter transformer (**Data Sheet 8.21 or 8.24**),
- metal-clad connection and junction elements (**Data Sheet 1.72**),
- metal-clad elements for PD measurement (**Data Sheet 1.73, 1.74 and 6.12**),
- computer control CMS 23 V (**Catalog Sheet 1.52 and related Data Sheets**),
- PD measuring systems (**Data Sheet 6.21 or 6.41**),
- optional: SF₆-to-air bushing (**Data Sheet 1.75**).

Test systems types WRVG...G are a technically perfect and economically optimum alternative to metal-clad transformer circuits when the variable frequency within a well defined frequency range is accepted. Considering a duty cycle of 15 min/day, the standard ratings are 325 kV/1.5 A, 460 kV/1.5 A, 540 kV/1.5 A, 680 kV/1.5 A, 750 kV/1.9 A and 1000 kV/0.65 A. For a duty cycle of 60 min/day, the currents must be reduced to half of the mentioned values.

Type designation for metal clad, gas-insulated resonant test system of variable frequency is WRVG a/b G, with "a" the rated current and "b" the rated voltage. Example: WRVG 1.5/680 G is a metal-clad, SF₆-insulated resonant test system with a reactor of 1.5 A and 680 kV.



Fig. 6: Test system WRVG 1.9/750 G for factory tests on GIS (courtesy of New Northeast Electric/China)

For further information please contact:

HIGHVOLT Prüftechnik Dresden GmbH

Marie-Curie-Strasse 10
D-01139 Dresden / Germany

Tel.: ++49 351 84 25-648

Fax: ++49 351 84 25-679

e-mail: dresden@highvolt.de

website: http://www.highvolt.de

or our local representative: