

Rods and Modules for Discharge and Earthing

Description rods for discharge and earthing :

Earthing rods are used for earthing, discharging and short-circuiting of test systems. The earthing rod (Fig. 1) is subdivided by a limitation disk into an isolating element (l_i) and a handle (l_h). The earthing and short-circuiting has a hook-shaped electrode and a 10 m earthing cable. It is permanently connected with the earthing rod.

For discharging capacitive objects a damped discharging rod ERS (Fig. 2), additionally equipped with a discharging resistor is available. Note: The test system has to be switched off before an earthing rod can be used. Earthing and discharge rods are only for use in indoor operation.

Technical Data:

type code		ES 1	ES 2	ES 3	ERS 1	ERS 2	
max. energy	kJ	(*)	(*)	(*)	8	8	
discharging resistor	Ω	0	0	0	500	500	
dischargeable capacitance	nF				175	175	
max. discharge	mC				100	100	
dimension							
	l_G	mm	1125	2125	3125	1740	2740
	l_H	mm	300	600	1000	300	600
	l_i	mm	700	1400	2000	700	1400
weight	kg	4	5	6	5	6	
application		earthing for ≤ 100 kV AC test systems	earthing for ≤ 200 kV AC test systems	earthing for ≤ 300 kV AC test systems	discharging and earthing for ≤ 135 kV DC test systems	discharging and earthing for ≤ 350 kV DC test systems	

(*) not suitable for discharging capacitive objects

Dimensional drawing:

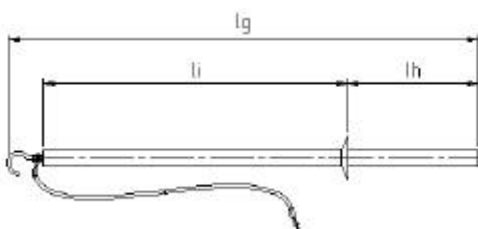

Fig.1: ES 1, ES 2, ES 3

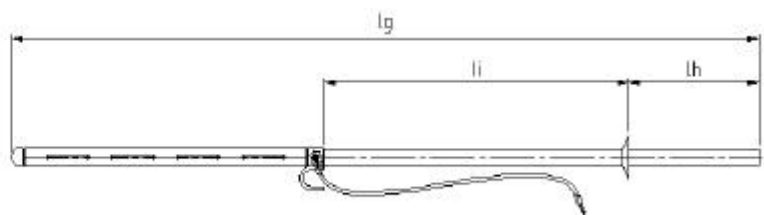

Fig. 2: ERS 1, ERS 2

Description modules for discharge and earthing:

Discharge and earthing of the test system can be achieved by using an electrical discharging device which works in conjunction with the control module. Alternatively direct earthing (Fig. 3: EE 150) or damped earthing (Fig. 4: ERE 150) is possible. For discharging capacitive objects the damped discharging device ERE 150, additionally equipped with a discharging resistor, has been designed. Both devices are rated at 150 kV.

The magnet driven devices EE 150 and ERE 150 can be used for single-stage HV

module test systems. They are equipped with an electromagnet, which is actuated by the respective control unit. For de-earthing, the magnet is energized and forces the discharging bar into the horizontal position. For earthing or discharging the power supply of the magnet is switched off together with the switching off of the high voltages the discharging bar due to the effect the counter-weight flips back into the vertical position. The discharging device is fixed to the base element FE 1 by means of a special bottom plate.

Technical Data:

type code		EE 150	ERE 150
max. voltage	kV	150	150
max. energy	kJ	(*)	0.2
discharging resistor	Ω	0	1000
Dischargeable capacitance	nF	-	20
max. discharge	mC	-	3
fit into grid		850	850
dimensions l	mm	840	840
b	mm	300	300
weight	kg	4.2	5
application		Earthing of AC \leq 150 kV	discharging and earthing of DC \leq 150 kV

(*) not suitable for discharging capacitive objects

Dimensional drawing:

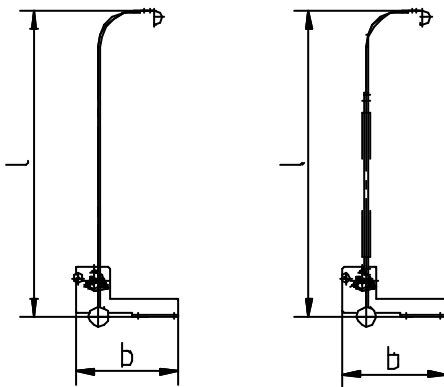

Fig. 3: EE 150

Fig. 4: ERE 150