

Data Sheet no. 4.13/7

Spark Gaps

Description test spark gap VF 1:

The test spark gap VF 1 can be used for all module systems in the grid 850 mm. Two spheres and a spindle gear with a hand wheel for the manual adjustments of the gap spacing are located in an insulating frame. One of the electrodes is fixed and the other electrode is adjustable between 0 to 75 mm. A motor driven test spark gap VF 2 is on request available.

Note that, for the standalone installation two base elements FE1, two insulating elements IE1 and two junction elements KE1 have to be ordered as well.

In the test spark gap a barrier frame can be included to demonstrate the effect of barriers. The barrier frame can hold an insulating screen, for example a sheet of paper.

Technical data:

Environmental conditions: temperature 5 to 40° C
relative humidity ≤ 90 %
indoor operation
(different parameters on request)

type code	rated voltage AC kV	rated voltage DC and Impulse voltage kV	dimensions (l x ød) mm	total weight kg
VF 1	100	135	722 x 235	5

Dimensional drawing

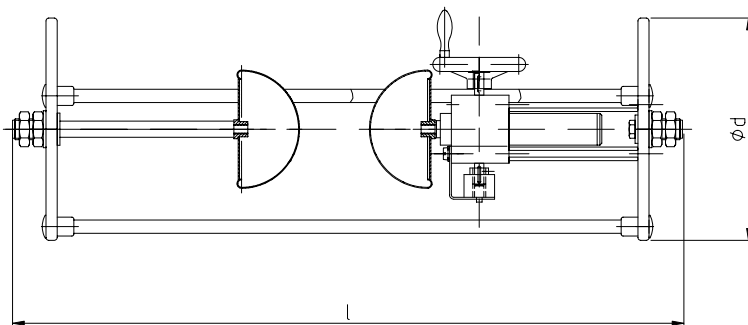

Fig. 1: VF 1

Description trigger spark gap TF 3:

The trigger spark gap TF 3 is used for impulse module systems.

Two spheres, a trigger generator and a spindle gear for the adjustments of the gap spacing are located in an insulating frame. The sphere with the trigger gap is fixed at the trigger generator, the non-triggered sphere is adjustable.

The drive is located below the spark gap between two base elements and contains the motor drive including the motor control for the gap spacing and the power supply unit. An insulating shaft forms the mechanical connection

between the spark gap and the drive.

The battery-fed trigger generator and the drive are controlled by the control and measuring system and receive the signals by fibre optic links to avoid electro-magnetic interferences completely.

The trigger spark gap fits in the 850 mm grid.

Note that, for the standalone installation two base elements FE1, two insulating elements IE1 and two junction elements KE1 have to be ordered separately.

Technical data:

type code	rated voltage DC and Impulse voltage kV	dimensions (l x ød) mm	total weight kg
TF 3	135	722 x 235	20

Environmental conditions: temperature 5 to 40° C
relative humidity ≤ 90 %
indoor operation
(different parameters on request)

Dimensional drawing

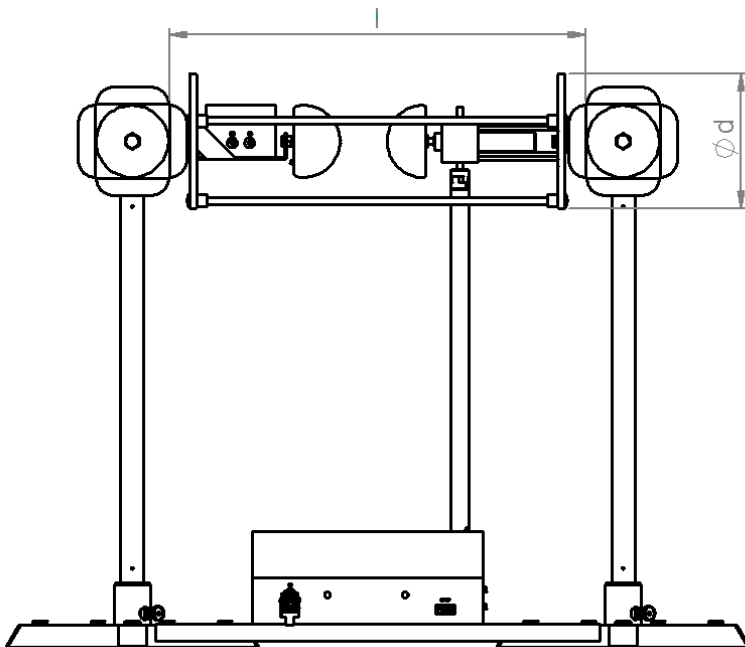

Fig. 2: TF 3