

Data Sheet no. 4.14/3

Test vessel, Type DG 100

Description test vessel DG 100

The pressure and vacuum test vessel serves to demonstrate the high-voltage performance in insulating gases depending on their pressure. Preferably, it is used in connection with the high-voltage module test system.

Dimensions are in accordance with the reference grid 850, connection thread is M 22 x 1.5.

The vessel itself is made of transparent material to observe the tests. The distance between the electrodes is adjustable.

The scope of supply includes:

- one set of exchangeable electrodes, consisting of semi-spherical electrodes (diameter 20 mm), rod and two needle electrodes,
- filling adapter and
- manometer.

For the separate installation with PD free high-voltage connection:

- one base element FE1,
 - one base connection element FV1,
 - one junction element KE1 and
 - one electrical connection, e.g. VE1
- have to be ordered as well.

Technical Data

Type description:	DG 100
Max. test voltage:	100 kV AC; 140 kV DC and impulse voltages
Operating overpressure:	3 bar or 5 bar
Volume:	4 l
Temperature:	5...35°C
Filling adapter:	DILO ½ Inch

Options

- vacuum pump
- SF₆-gas handling device
- different dimensions and electrodes upon customer's request

Dimensional drawing

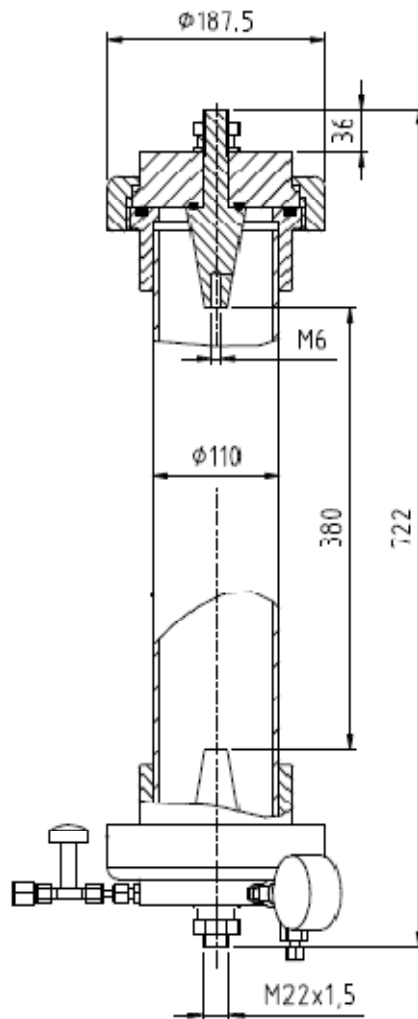

For further information please contact:

or our local representative:

HIGHVOLT Prüftechnik Dresden GmbH
Marie-Curie-Strasse 10

D-01139 Dresden / Germany

Tel. +49 351 8425-648
Fax +49 351 8425-679
e-mail dresden@highvolt.de
website <http://www.highvolt.de>