

Data Sheet no. 5.24/5

Universal Resistive / Capacitive Reference Voltage Divider Type MCR ... ref

Application

The Universal Resistive/ Capacitive Reference Voltage Dividers are designed for the precise measurement of Alternating (AC), Direct (DC), Lightning (LI) and Switching Impulse (SI) Voltages. They are the basic components of Universal Voltage Reference Measuring Systems for calibration purposes according to IEC 60060-2.

Design

The divider is based on a special measuring capacitor with a new mixed dielectric, which guarantees a high stability of the capacitance at both, alternating voltage and impulse voltage, too. There are damping resistors arranged between the internal single HV capacitor packages. Further carefully adjusted damping resistors are located inside the low voltage part and at the beginning of the high voltage lead. After the adjustment procedure the damping resistors guarantee an excellent dynamic behavior of the divider, which meets the recommendations of IEC 60060-2 for reference dividers.

For the measurement of DC voltage the divider has an additional resistive parallel path. The high voltage high-ohmic resistors are arranged in parallel with the separate capacitor stack or in one tube with the capacitor stack.

The divider is equipped with a PD free top electrode and a base frame with rollers.

The voltage is applied to the divider over a lead with damping resistor at the beginning.

Instruments

Beside the Universal Resistive/ Capacitive Voltage Divider the instruments for the Reference Measuring Systems may be delivered, too, e.g. the digital impulse analyzer type MIAS for impulse voltage measurement (Catalog Sheet 5.60) and peak voltmeter MU for AC and DC voltage measurement (Data Sheet 5.56).

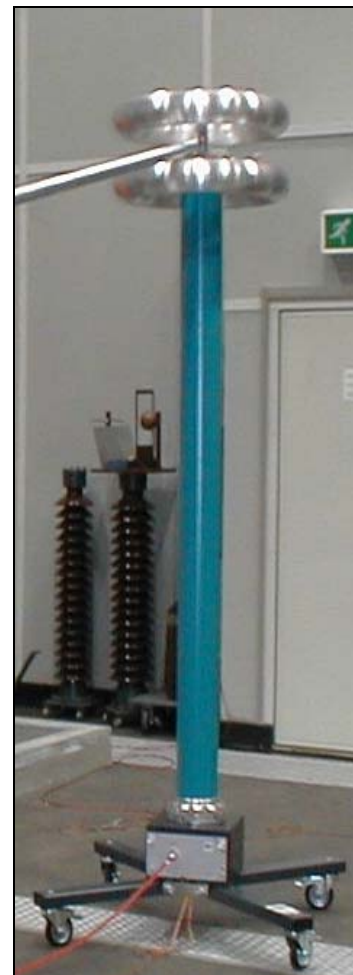

Figure 1: MCR 0.6/500-500/200 ref

Option

For the application of the divider and the instrument for on-site calibrations special transportation boxes can be delivered on request.

Type designation:

MCR a/b-c/d a = C in nF
 b = LI peak in kV
 c = R in MΩ
 d = AC voltage in kV

Technical data

Type MCR	C [pF]	R [MΩ]	LI voltage (peak) [kV]	SI voltage (peak) [kV]	AC voltage (45 ... 65 Hz) (rms)[kV]	DC voltage (peak) [kV]	AC/DC duration [min]	divider ratio
0.5/200-100/40 ref**	500	100	200	200	40	40	30	220
1/300-300/100 ref**	1000	300	300	300	100	100	30	300
0.6/500-500/200 ref**	600	500	500	500	200	200	30	500
0.375/800-700/400 ref**	375	800	800	700	400	400	30	2000
* design: capacitor tube in parallel with separate resistor tube								
** design: capacitors and resistors in one tube								
Dynamic behavior: The parameters of the step response are inside the following limits:			experimental response time T_N : first partial response time T_α : settling time t_s : overshoot β :				15 ns 30 ns 200 ns 10 %	
Measuring uncertainty of voltage: Measurement for a probability level of 95 %: (under reference working conditions)			lightning impulse voltage full waves and waves chopped after the peak (\hat{U} and scale factor): switching impulse voltage (\hat{U} and scale factor): alternating voltage ($\hat{U} / \sqrt{2}$ and scale factor): direct voltage (average and scale factor):				≤ 0.7 % ≤ 0.7 % ≤ 0.7 % ≤ 0.7 %	
Measuring uncertainty of time parameter Measurement for a probability level of 95 %: (under reference working conditions and under condition of the measurement of the divider output voltage with a digital impulse analyzer MIAS):			lightning and switching impulse voltage				≤ 5 %	
Metrological characteristics:			voltage dependent non-linearity: short term instability at AC/DC rated voltage and operating time 30 min: long term instability over 1 year: temperature coefficient of the scale factor:				≤ 0.3 % ≤ 0.2 % ≤ 0.5 % ≤ 0.03 %/K	
Installation:			indoor to keep the temperature range					
Reference working conditions:			temperature: relative humidity:				15 °C ... 30 °C < 80 %	
Operating working conditions:			temperature: relative humidity:				5 °C ... 40 °C < 80 %	
Type of socket at the divider:			N-type					
The following accessories belong to the content of delivery:			<ul style="list-style-type: none"> • high voltage lead • damping resistor (arranged at the beginning of the lead) • measuring cable (wave resistance 50 Ohm, length 25 m, double screened) • documentation (record of performance according to IEC 60060-2) 					

Dimensions and weight

Type MCR	H [mm]	A x A [mm]	Length HV-lead L [mm]	Weight [kg]
0.5/200-100/40 ref	1200	650 x 650	1450	41
1/300-300/100 ref	1950	1000 x 1000	2300	52
0.6/500-500/200 ref	2527	1228 x 1228	2440	80
0.375/800-700/400 ref	3090	1590 x 1590	2605	132

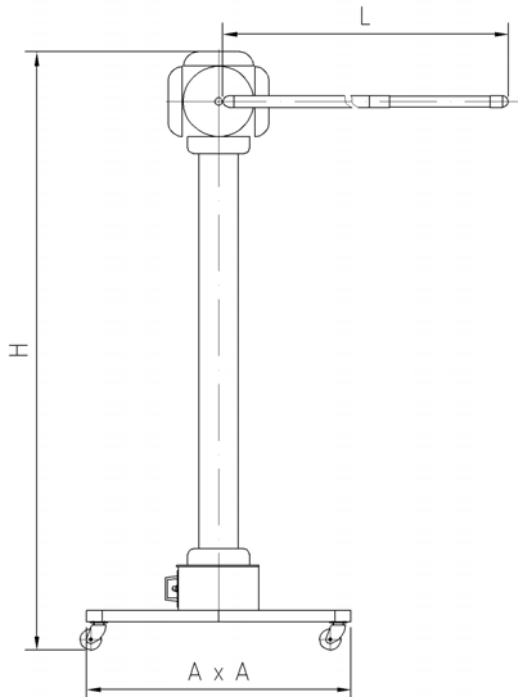

Figure 2: Dimensional drawing

Calibration

The Universal Resistive/ Capacitive Reference Voltage Dividers are calibrated by the HIGHVOLT calibration laboratory DKD-K-24501. The calibration is documented by a DKD-calibration certificate. This calibration certificate documents the traceability to national standards, which realize the units of measurements according to the International System of Units (SI).

The DKD is signatory to the multilateral agreements of the European co-operation for Accreditation (EA) and of the International Laboratory Accreditation Cooperation (ILAC) for the mutual recognition of calibration certificates.

If the application task demands a calibration at a National Institute for Metrology on request the Universal Resistive/ Capacitive Reference Voltage Dividers would be calibrated at the Physikalisch-Technische Bundesanstalt (PTB).

It is recommended to calibrate the Universal Resistive/ Capacitive Reference Voltage Dividers together with the related instruments.

Example:

MCR 1/300-300/100 ref means:
reference divider with HV arm of 1 nF for 300 kV lightning, 300 kV switching impulse voltage and 100 kV for AC voltage (r.m.s.) and DC voltage each

For further information please contact:

or our local representative:

HIGHVOLT Prüftechnik Dresden GmbH
Marie-Curie-Strasse 10

D-01139 Dresden / Germany

Tel. +49 351 8425-648
Fax +49 351 8425-679
e-mail dresden@highvolt.de
website <http://www.highvolt.de>