

**HIGH
VOLT**

Partial Discharge Measurement System
PiDAS MPD 600



General Information

Application

Partial discharge (PD) measurement is one of the most important non-destructing methods for the detection of insulation defects in electrical power equipment. The breakdown of insulation materials occurs at their weak points, which usually show PD activity before. Thus, PD detection can help to prevent cost-intensive damage and therefore, it is used for quality tests and diagnostics in factory as well as on-site testing of cables, GIS, power and instrument transformers or rotating machines and their components.

The partial discharge analysis system **PiDAS MPD 600** offers high-resolution digital processing technology, which provides outstanding measurement accuracy. The system can be used for all test objects in case of standard PD measurement.

Three Phased Transformer Testing

Connecting several acquisition units allows three-phase PD measurement on HV transformers. Decoupling PD pulses at high and low voltage taps of a transformer allows observation of cross-coupling PD signals between the phases.

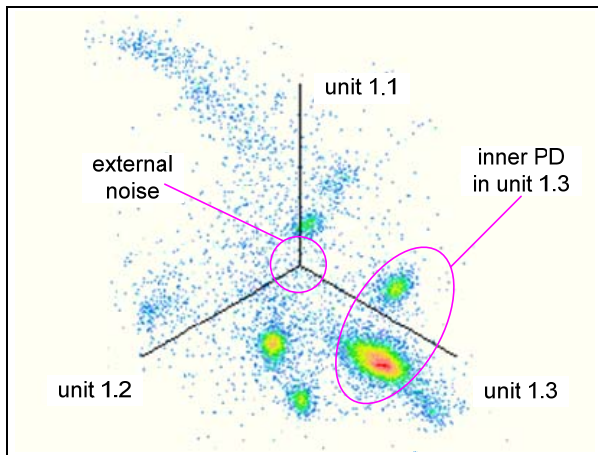

Fig. 1: 3-Phase Amplitude Relation Diagram (3PARD)

Voltage and PD data can be recorded in real time and displayed together synchronously or each phase separately. Thus, the phasing of the PD is easily recognizable.

On-site Cable Testing

In addition to observation of PD signals, PD faults can be located at their point of appearance by TDR algorithms (Time Domain Reflectometry). The TDR method analyzes the time delay between reflection or propagation signals of PD pulses and calculate the distance from the cable end to the PD source.

Situating one acquisition unit at each cable end (dual end method) delivers an exceptional accuracy of up to less than 0.2 % of the cable length, depending on the cable length and its attenuation.

Alternative decoupling methods based on field sensors give the possibility to take measurement at cable joints or CB links, especially for cable lengths of more than 1...2 km. This kind of PD detection results in a higher

Measuring Circuit

sensitivity than detection at cable ends. The sensor interconnection by using fiber optic links of up to 2 km allows to place the acquisition units at the cable joints to test the quality of the complete cable length after laying.

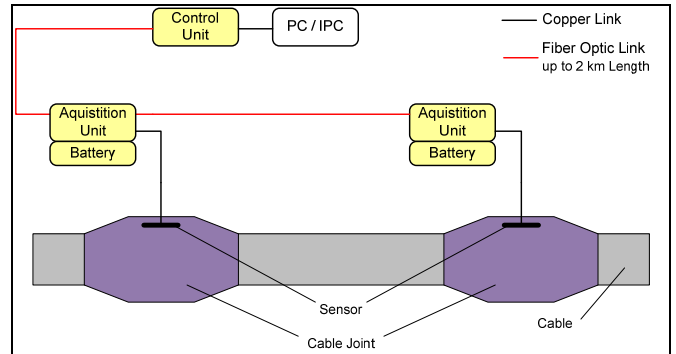

Fig. 2: Test setup for on-site cable testing

GIS Testing

The wide range of multiple applications of the PD measuring system PiDAS allows an outstanding PD signal detection at GIS and GIL components and systems. In addition to the PD detection by capacitive coupling, the measuring system can be used for UHF and ultrasonic PD detection. Therefore, separate sensor units and adapted acquisition software tools can be offered.

PD Measuring Circuit

The general requirements for PD measurement according to the **IEC Standard 60270** consider the PD circuit, the measuring instruments, the calibration and the measuring procedures (Fig. 3).

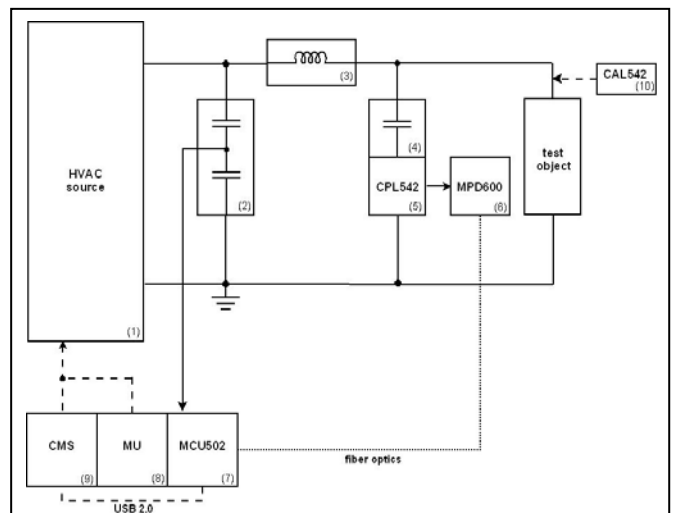

Fig. 3: PD measuring circuit according to IEC 60270

(1) HV source	(6) Acquisition unit
(2) Voltage divider	(7) Control unit
(3) Blocking impedance	(8) Peak voltmeter
(4) PD coupling capacitor	(9) Computer control
(5) Measuring impedance	(10) Calibrator

System Components

PiDAS MPD 600 is a modular, data acquisition and analysis system consisting of a PC-operated control unit (7), type MCU 502, 504 or 550, and one or more acquisition units (6) type MPD 600, connected via fiber optics. Each acquisition unit is connected to a sensor and supplied by a battery-pack, type MPP 600. The main advantages of the fiber-optic network technology are:

- Complete electrical insulation between the acquisition units,
- Elimination of ground loops,
- Up to 960 fully synchronous channels.

Furthermore, the battery-supplied PD detectors can be placed close to the coupling device (4), which reduces the length of the BNC connection and consequently the noise and interferences.

Acquisition Unit PiDA MPD 600:

The acquisition units (Fig. 4) are linked with the control unit via fiber optics. Up to 960 acquisition units can be connected for synchronous multichannel measurement. The power is supplied by power packs of type PiDA MPP 600.



Fig. 4: Acquisition Unit PiDA MPD 600

Material	Extruded aluminium
Dimensions (mm)	110 (W) x 190 (D) x 44 (H)
Power supply	8 - 12 V DC Power consumption: 4 W (max.) < 10 mW (idle)
Indicators	LED for stand-by, power, status, data integrity
Connectors	2 x fiber optical network 1 x PD input (BNC) 1 x Voltage input (BNC)
Input frequency range	Voltage: 0 Hz - 4.3 kHz PD: 0 Hz - 20 MHz
Input impedance	Voltage: 1 μ F / 1 M Ω PD: 50 Ω
Input voltage	Voltage: 60 V rms (max) PD: 10 V rms (max)

Dynamic range	Voltage: 102 dB PD: 132 dB (overall) 70 dB (per range)
PD input range control	11 level (7.4 dB gain/level)
PD input protection	Protection against overcurrents and surges
PD input coupling options	DC, AC or external pre-amplifier
Measurement uncertainty	Voltage: \pm 0.05 % Frequency: \pm 1 ppm PD level: \pm 2 %
Additional features	Built-in quadripol $C_{LV} = 1 \mu$ F
Environment Conditions	Temperature: 0°C - 55°C Rel. humidity: 5% - 100% (non condensing)

Control Unit PiDA MCU 502:

The control unit (Fig. 5) is connected to a PC or laptop via USB 2.0, an additional power supply is not necessary. A built-in light sensitive trigger enables synchronization with the power frequency.



Fig. 5: Control Unit PiDA MCU 502

Material	Extruded aluminium
Dimensions (mm)	110 (W) x 180 (D) x 30 (H)
Power supply	Bus powered via USB
Connectors	USB 2.0, fiber optical network
Indicators	1 LED (USB connection / Error)
Light sensitive trigger	50 - 60 Hz

Battery Pack PiDA MPP 600:

The battery package supplies the acquisition unit for approximately 8 hours with the necessary energy.

Material	Extruded aluminium
Dimensions (mm)	110 (W) x 170 (D) x 28 (H)
Battery type	11 V, 4.8 Ah, Li-On Rechargeable

Data Evaluation

The delivered software iDAS gives the possibility to control the connected acquisition units and to visualize all recorded and evaluated data in real time.

Base Software iDAS

The self-explanatory software running on a PC allows rapid and simple evaluation of the PD level to verify the conformance to requirements, e.g. EN, IEC or manufacturer's standards.

Data storage and generation of test records can proceed automatically. The base software iDAS also offers session replay, which allows extensive off-line analysis that is not bound by real-time computational constraints.

iDAS is designed to work in an integrated environment together with HIGHVOLT control to enrich it with functionalities for fully automatic partial discharge measurement. This includes improved possibilities in reporting.

iDAS-TRA

The additional software package for transformer tests supports a special transformer-testing mode with adapted analyzing tools, e.g. 3-PARD© (see Fig. 1). The recording of phase resolved PD patterns and a synchronous display of several acquisition units are additional valuable facilities.

iDAS-CAB

The software package iDAS-CAB supports a special cable measuring mode.

The **iDAS-CAB-Factory** expansion offers an intuitive step-by-step interface which keeps the effort and possible errors during operation to a minimum. Advanced features allow the user to manually control necessary aspects of the PD detection and analysis process, and provide access to detailed visualization options.

The **iDAS-CAB-OnSite** software offers additional options for noise reduction with the help frequency filters, windowing functions and gating with additionally connected units (Fig. 6).

iDAS-GIS

The software **iDAS-GIS-Factory** and **iDAS-GIS-OnSite** supports special GIS testing modes with adapted user interfaces.

Accessories

Features

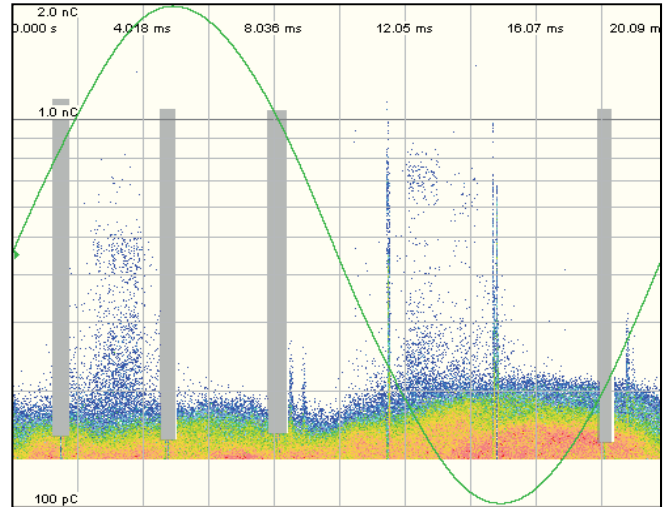

Fig. 6: Gated disturbance pulses

Basic accessories

For a complete PD measuring system for general application the PiDAS MPD 600 system has to be completed by

- A number of measuring impedances equal to the number of acquisition units, e.g. type PiDA CPL 542,
- One PD calibrator, e.g. type PiDA CAL 542,
- One or more inductive sensors, which can also be used for gating purposes.

Standard features

- Light sensitive trigger for calibration (50 Hz / 60 Hz),
- Internal trigger for calibration (free freq. range),
- Phase and phase amplitude gating (windowing),
- Unit gating,
- Voltage and charge calibration,
- Digital low - pass filter on PD input,
- RIV measurement possible,
- Q(U) display,
- Recording and replay of complete measurement sessions,
- Screenshot generation.

Additional features

Different sets of accessories enable an optimum adaptation to special test objects and test conditions. For further details see the data sheets available on our website or contact us directly.

For further information please contact:

HIGHVOLT Prüftechnik Dresden GmbH
Marie-Curie-Strasse 10
D-01139 Dresden / Germany

Telephone: ++49 351 84 25-648
Fax: ++49 351 84 25-679

e-mail: sales@highvolt.de
website: www.highvolt.de

or our local representative: