

Data Sheet no. 8.15/2

## High Power Modular-Type Reactors, Types DEI

### Description

This type of modular reactors has been developed for the use in resonant test systems with variable frequency for on-site testing of larger GIS, short cables and other components, or may be used as HV compensation reactors.

The modular design enables to form cascades up to three modules as well as the parallel connection of several modules or cascades, and thereby an optimum adaptation to the test voltage and test object capacitance.

The reactors are designed for frequent truck transportation and temporarily outdoor operation under dry weather conditions. Temporary outdoor operation, e. g. for HV on-site testing, can be guaranteed by using a silicon based coating.

The multi-gap core is made of high-quality grain-oriented transformer sheet and enables together with the layer-type windings a high quality factor of the resonant circuit. The iron core of the reactor is connected to the midpoint potential of the HV winding. The oil filled case is fibreglass reinforced plastic (FRP) tube with steel covers. The core design guarantees that ambient steel constructions are not influenced by the magnetic flux of the reactors.

The realised long term duty cycles allow performing more than one test per day.

The data in the table are valid for ambient temperature up to 40°C.

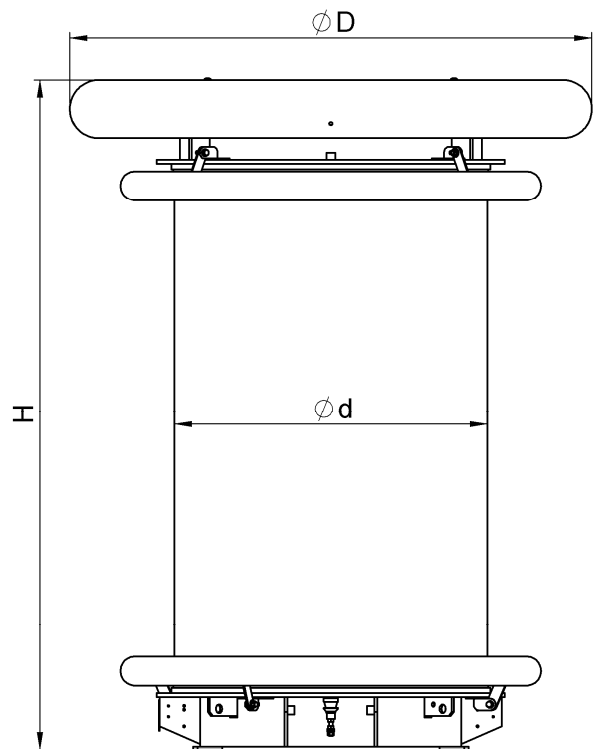

Fig. 1 Principle drawing

Type	Voltage kV	Inductance H	Current A	Frequency range Hz	Load capacitance at max. voltage nF	Lowest frequency at max. voltage Hz	Highest voltage at 25 Hz kV	Duty cycle per day <sup>1)</sup>	Height H/mm	Tube diameter d/mm	Electrode diameter D/mm	total weight kg	weight of oil kg
DEI 3200/160-10	160	102	10	25 - 300	397 – 2.76	25	160	3x 0.5h ON / 2h OFF @ 20 °C	1750	1080	1450	2650	990
DEI 600/200-3	200	212	3	25 - 300	47 – 1.32	50	100	3x 1h ON / 3h OFF	1700	840	1200	1800	550
DEI 1200/200-6	200	106	6	25 - 300	95 – 2.65	50	100	3x 1h ON / 1h OFF	1750	1080	1450	2400	950
DEI 2000/200-10	200	64	10	25 - 300	159 – 4.42	50	100	3x 1h ON / 2h OFF	1850	1080	1450	2600	1000
DEI 750/250-3	250	265	3	25 - 300	38 – 1.06	50	125	3x 1h ON / 3h OFF	2200	840	1200	2000	550
DEI 1500/250-6	250	133	6	25 - 300	76 – 2.12	50	125	3x 1h ON / 1h OFF	2200	1080	1450	2900	1080
DEI 2500/250-10	250	80	10	25 - 300	127 – 3.53	50	125	3x 1h ON / 2h OFF	2350	1080	1450	3700	1200
DEI 1000/300-3.33	300	287	3.33	25 - 300	35 – 0.98	50	150	3x 1h ON / 1h OFF	2220	1080	1450	3300	1200
DEI 1500/300-5	300	191	5	25 - 300	53 – 1.47	50	150	3x 1h ON / 2h OFF	2420	1080	1450	3500	1340
DEI 3000/300-10	300	95	10	25 - 300	106 – 2.94	50	150	3x 1h ON / 3h OFF	2550	1260	1800	4700	1600
DEI 1000/350-3	350	327	3	25 - 300	24 – 0.86	57	155	3x 1h ON / 1h OFF	2390	1080	1800	3350	1200
DEI 1200/400-3	400	424	3	25 - 300	23 – 0.66	50	200	3x 1h ON / 1h OFF	2650	1080	1450	3300	1400
DEI 2000/400-5	400	255	5	25 - 300	39 – 1.1	50	200	3x 1h ON / 2h OFF	2700	1260	1800	5200	2100
DEI 3000/400-7.5	400	170	7.5	25 - 300	59 – 1.65	50	200	3x 1h ON / 3h OFF	2700	1260	1800	5500	2000

Explanations: Electrode diameters are related to single insulating case reactors. To form cascades with higher voltages, special top electrodes are necessary. Modification of technical data on request.

1) The duty cycle depends on the load. The given duty cycles are related to the max. current and 40°C ambient temperature, except first type of the table. For reduced current longer duty cycles can be used. Information is supplied on special request.

For further information please contact:  
**HIGHVOLT Prüftechnik Dresden GmbH**  
 Marie-Curie-Straße 10

or our local representative:

**D-01139 Dresden / Germany**  
 Tel. +49 351 8425-648  
 Fax +49 351 8425-679  
 e-mail dresden@highvolt.de  
 website http://www.highvolt.de