

Data Sheet no. 8.31/1

## Control and Feeding Unit RSE 70 for Resonant Test Systems of Variable Frequency

### Description:

The control and feeding unit RSE 70 is used for the manual or automatic control of frequency-tuned series resonant test systems. With respect to its output power it is especially designed for the on-site testing of gas-insulated substations (GIS), medium voltage cables and power generators.

The heart of the RSE 70 is a frequency inverter bridge with an intermediate voltage circuit (Fig. 1). The three-phase line voltage is rectified and the direct voltage is buffered by a capacitor bank. The following frequency inverter generates a square-wave voltage of adjustable frequency and pulse-width. The inverter bridge is designed from power transistors (IGBT's) and is driven by a micro-controller. The test sequence and the supervision of

the complete test system is controlled by a PLC type SIMATIC S7. An operator panel with LCD display is used for the data input and the display of preselected and measured parameters or other information. The test voltage value is measured by a built-in peak voltmeter, type MU 18 (Catalogue Sheet 5.56).

In an automatic mode the resonant frequency of the test circuit is determined at small pulse width ( low output voltage) at the beginning of each test. After that the pulse width is increased until the test voltage reaches the preselected value. Now a counter is started for the test duration, which will terminate the test after the preselected time. The automatic procedure can be interrupted at any time to change the preselected values, e.g. test voltage or frequency.

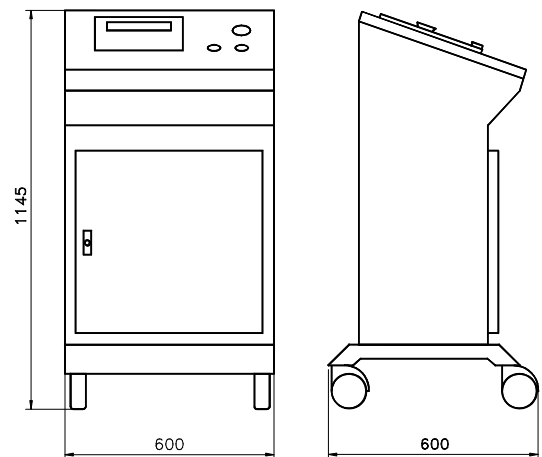
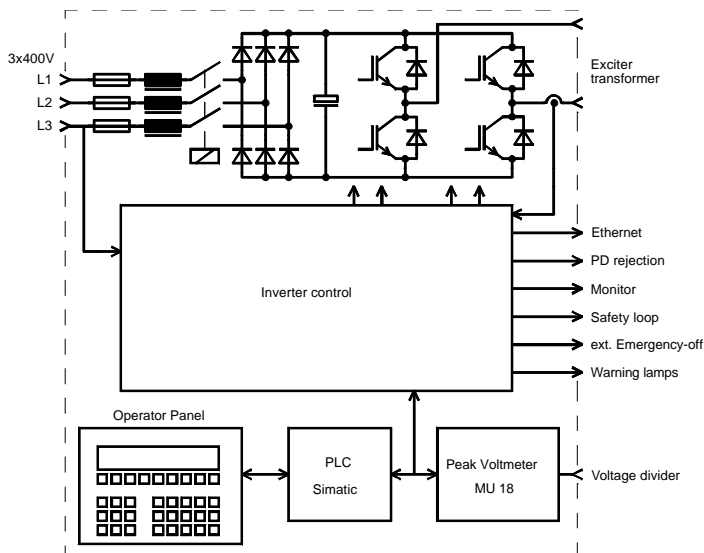

Fig. 1 (left) : Principle circuit diagram RSE 70

Fig. 2 (above) : Dimensions of RSE 70

Test object and test system are protected against misoperations, feeding voltage changes, overload, breakdowns of the test objects and other critical events by safety measures as e.g. voltage or current limiters.

Optional an external PC (e.g. a notebook computer) can be connected to the RSE 70 via a network connection (Ethernet). This enables the remote control, the test parameter (voltage, frequency, currents, etc.) recording and evaluation as well as the printing of a test report.

Because PD measurement could be disturbed by the switching transients of the IGBT's, the RSE 70 supplies a gate-off signal of some 10  $\mu$ s (adjustable duration) which can disable the PD measurement for that short moment.

All components of the RSE 70 are built in a movable desk (Fig. 2). The operator panel and the emergency-off button are on the top of the desk. All electrical connections can be plugged, the related sockets are submerged on the backside.

### Main Parameters of the RSE 70

#### Connections

Supply voltage, three-phase 230/400 V  $\pm$  10%, 50/60 Hz  
Supply power 50 kVA

#### Output parameters

voltage range 10 ... 550 V<sub>eff</sub>  
rated current 70 A  
frequency range 18 ... 300 Hz

#### Displayed measured parameters

High voltage  
resolution 4 digits  
measuring uncertainty < 1 %  
Frequency  
resolution 10 mHz

#### Interfaces for control

Input for external voltage divider  
input resistance 10 M $\Omega$   
max. input voltage 100 V<sub>eff</sub>  
Emergency-off and safety loop  
operation voltage 230 V<sub>AC</sub>  
Contact for warning lamps  
voltage / current 230 V<sub>AC</sub>, max. 5 A  
PD gate-off signal  
output voltage 5 V (TTL- level)  
duration 10 ... 630  $\mu$ s, adjustable in steps of 10  $\mu$ s

#### Dimensions, Weight, Environment

Dimensions (W x H x D) 600 mm x 1145 mm x 600 mm (Fig. 2)  
Weight 100 kg  
Temperature / humidity +5 ... +40 °C / < 90 %

For further information please contact:

or our local representative:

#### HIGHVOLT Prüftechnik Dresden GmbH

Marie-Curie-Straße 10

#### D-01139 Dresden / Germany

Tel. ++49 351 8425-648  
Fax ++49 351 8425 679  
e-mail dresden@highvolt.de  
internet http://www.highvolt.de