

Data Sheet no. 8.33/2

Control and Feeding Unit RSE 400 for Resonant Test Systems of Variable Frequency

Description

The control and feeding unit RSE 400 is used for the manual or automatic control of frequency-tuned series resonant test systems. With respect to its output power it is especially designed for the on-site testing of long HV and EHV voltage cables and gas-insulated lines (GIL).

The heart of the RSE 400 is a frequency inverter bridge with an intermediate voltage circuit (Fig. 1). The three-phase line voltage is rectified and the direct voltage is buffered by a capacitor bank. The following frequency inverter generates a square-wave voltage of adjustable frequency and pulse-width. The inverter bridge is designed from power transistors (IGBT's) and is driven by a micro-controller. The test sequence and the supervision of the complete test system are controlled by a programmable logic controller (PLC) type SIMATIC S7.

An operator panel with LCD display is used for the data input and the display of preselected and measured parameters or other information. The test voltage is measured by a built-in peak voltmeter type MU 18 (Data Sheet 5.56).

In an automatic mode the resonant frequency of the test circuit is determined at small pulse width (low output voltage) at the beginning of each test. After that the pulse width is increased until the test voltage reaches the preselected value. Now a counter is started for the test duration, which will terminate the test after the preselected time. The automatic procedure can be interrupted at any time to change the preselected values, e.g. test voltage or frequency.

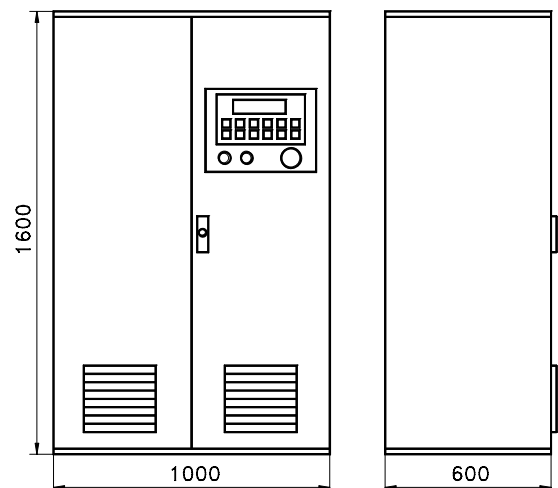
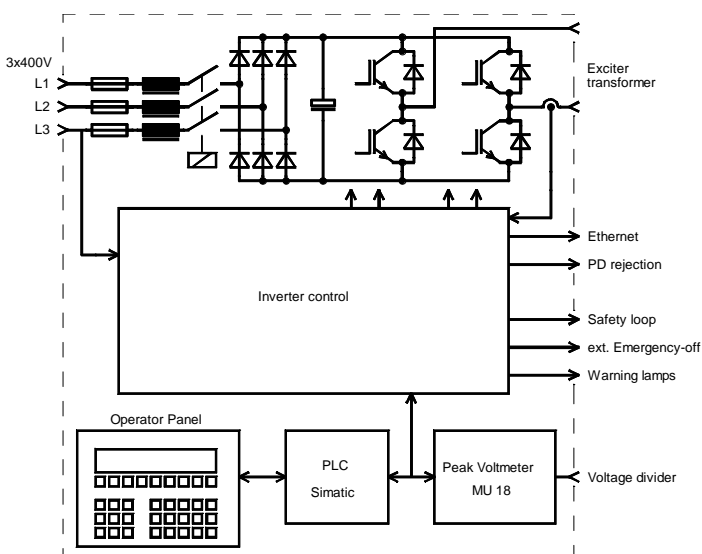

Fig. 1 (left) : Principle circuit diagram RSE 400

Fig. 2 (above) : Dimensions of RSE 400

Test object and test system are protected against misoperation, feeding voltage changes, overload, breakdowns of the test objects and other critical events by safety measures as e.g. voltage or current limiters and a fast switch-off device.

Optionally, an external PC (e.g. a notebook computer) can be connected to the RSE 400 via a network connection (Ethernet). This enables the remote control, the test parameter (voltage, frequency, current, etc.) recording and evaluation as well as the printing of a test report.

Because PD measurement could be disturbed by the switching transients of the IGBT's, the RSE 400 supplies a gate-off signal of some 10 μ s (adjustable duration) which can disable the PD measurement for that short period.

All components of the RSE 400 are built in a cubicle with two front doors (Fig. 2). The operator panel and the emergency-off button are submerged in the right door. Most of the connections can be plugged; the related sockets and busbars are installed immersed on the rear.

Main Parameters of the RSE 400

Connections

Supply voltage, three-phase 230/400 V \pm 10 %, 50/60 Hz
Supply power 300 kVA

Output parameters

Voltage range (r.m.s.) 10 ... 520 V
Rated current 400 A
Frequency range 10 ... 150 Hz / 20 ... 300 Hz

Displayed measured parameters

High voltage
Resolution 4 digits
Measuring uncertainty < 1 %
Frequency
Resolution 10 mHz

Interfaces for control

Input for external voltage divider
Input resistance 10 M Ω
Max. input voltage (r.m.s.) 100 V
Emergency-off and safety loop
Operation voltage 230 V AC
Contact for warning lamps
Voltage / current 230 V AC / max. 5 A
PD gate-off signal
Output voltage 5 V (TTL- level)
Duration 1 ... 1000 μ s

Dimensions, Weight, Environment

Dimensions (W x H x D) 1000 mm x 1600 mm x 600 mm (Fig. 2)
Weight 330 kg
Temperature / Humidity +5 ... +40 $^{\circ}$ C / < 90 %

For further information please contact:

or our local representative:

HIGHVOLT Prüftechnik Dresden GmbH
Marie-Curie-Strasse 10

D-01139 Dresden / Germany
Tel. +49 351 8425-648
Fax +49 351 8425-679
e-mail dresden@highvolt.de
website <http://www.highvolt.de>