

Data Sheet no. 8.34/2

Control and Feeding Unit RSE 800 for Resonant Test Systems of Variable Frequency

Description

The control and feeding unit RSE 800 is used for the manual or automatic control of frequency-tuned series resonant test systems. With respect to its output power it is especially designed for the testing of very long HV and EHV voltage cables.

The heart of the RSE 800 is a frequency inverter bridge with an intermediate voltage circuit (Fig. 1). One frequency inverter and the complete control are arranged in a switching cabinet. This is the so-called "master" which corresponds to the Control and Feeding Unit RSE 400 (Data Sheet 8.33) with respect to the control functions and the internal design. A second cabinet, directly flanged to the master, contains a second frequency inverter which is the "slave" and uses the control signals from the master. Consequently it is not equipped with its own operator panel.

The output of the two frequency inverters must be transferred to two identical adapter transformers. An operator panel with LCD display is used for the data input and the display of pre-selected and measured parameters or other messages. The test voltage is measured by a built-in peak voltmeter type MU 18 (Data Sheet 5.56).

In an automatic mode the resonant frequency of the test circuit is determined at small pulse width (low output voltage) at the beginning of each test. After that the pulse width is increased until the test voltage reaches the preselected value. Now a counter is starting for the test duration, which will terminate the test after the preselected time. The automatic procedure can be interrupted at any time to change the preselected values, e.g. test voltage or frequency.

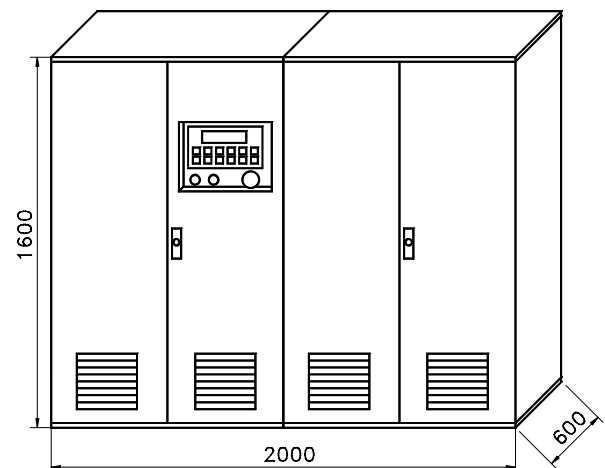
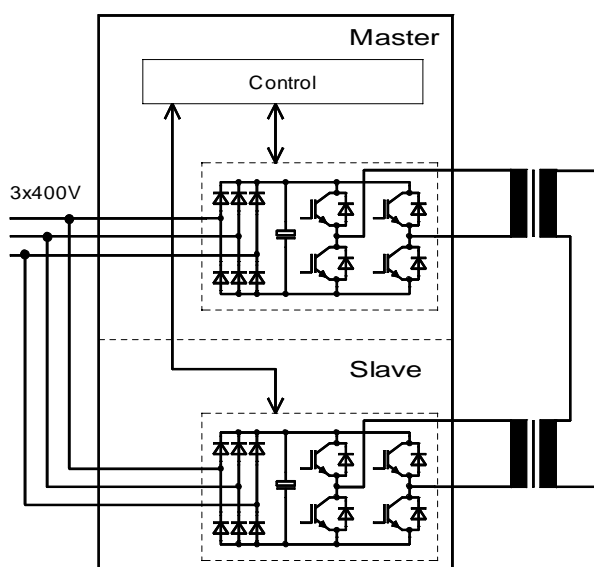

Fig. 1 (left) : Principle circuit diagram RSE 800

Fig. 2 (above) : Dimensions of RSE 800

Test object and test system are protected against misoperation, feeding voltage changes, overload, breakdowns of the test objects and other critical events by safety measures as e.g. voltage or current limiters and a fast switch-off device.

Optional an external PC (e.g. a notebook computer) can be connected to the RSE 800 via a network connection (Ethernet). This enables the remote control, the test parameter (voltage, frequency, current, etc.) recording and evaluation as well as the printing of a test report.

Because PD measurement could be disturbed by the switching transients of the IGBT's, the RSE 800 supplies a gate-off signal of some 10 μ s (adjustable duration) which can disable the PD measurement for that short period.

All components of the RSE 800 are built in a cubicle with two front doors (Fig. 2). The operator panel and the emergency-off button are submerged in the right door. Most of the electrical connections can be plugged; the related sockets and busbars are submerged on the backside.

Main Parameters of the RSE 800

Connections

Supply voltage, three-phase 230/400 V \pm 10 %, 50/60 Hz
 Supply power 600 kVA

Output parameters

Voltage range (r.m.s.) 10 ... 520 V
 Rated current 800 A
 Frequency range 10 ... 150 Hz / 20 ... 300 Hz

Displayed measured parameters

High voltage
 Resolution 4 digits
 Measuring uncertainty < 1 %
 Frequency
 Resolution 10 mHz

Interfaces for control

Input for external voltage divider
 Input resistance 10 M Ω
 Max. input voltage (r.m.s.) 100 V
 Emergency-off and safety loop
 Operation voltage 230 V AC
 Contact for warning lamps
 Voltage / Current 230 V AC / max. 5 A
 PD gate-off signal
 Output voltage 5 V (TTL- level)
 Duration 1 ... 1000 μ s

Dimensions, Weight, Environment

Dimensions (W x H x D) 2000 mm x 1600 mm x 600 mm (Fig. 2)
 Weight 600 kg
 Temperature / Humidity +5 ... +40 $^{\circ}$ C / < 90 %

For further information please contact:

or our local representative:

HIGHVOLT Prüftechnik Dresden GmbH

Marie-Curie-Strasse 10

D-01139 Dresden / Germany

Tel. +49 351 8425-648
 Fax +49 351 8425-679
 e-mail dresden@highvolt.de
 website <http://www.highvolt.de>